

The Microcor<sup>®</sup> corrosion monitoring technology has been developed to substantially increase the speed of response over conventional monitoring techniques, such as coupons, electrical resistance (ER) probes, and linear polarization resistance (LPR), and is functional in all environments.



**Microcor Transmitter and Retractable Probe in Field Installation**

Microcor is the result of patented technology which combines the rapid response of LPR and the universal applicability of ER. The figure below compares the real world response of various corrosion monitoring methods to the Microcor system.

Corrosion rate on a logarithmic scale is plotted against time, also on a logarithmic scale. At 10 mpy, the common T20 electrical resistance probe takes nearly 3 days to show a clear response. A Microcor probe with the same useful probe life will show a clear response in 1 hour, and the trend is visible in 15 minutes. Even an LPR probe in water will take 5 to 10 minutes to produce a steady corrosion rate reading. This means that the Microcor system is 50 to 100 times more sensitive and faster in response than ER systems. The absolute resolution of the Microcor electronics is 256 times more sensitive than ER system electronics.

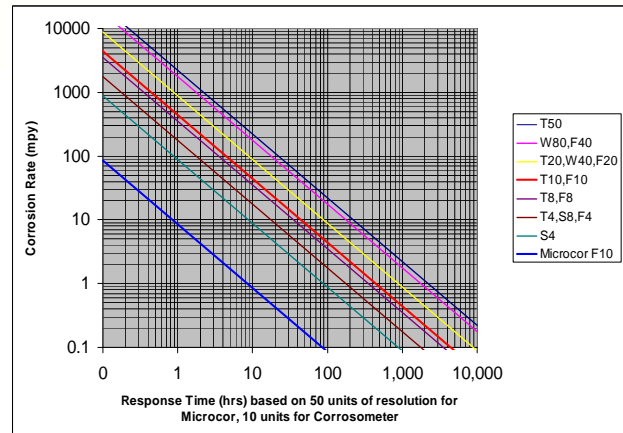

**Increased Speed of Response of Microcor Systems**

The Microcor measurement is based fundamentally on metal loss and is therefore directly comparable to ER probe data and coupon data. It does not depend on the empirically determined electrochemical constants of LPR measurements, or the complex and variable analysis of electrochemical noise techniques, both of which require an electrically conductive solution for accurate measurements.

The active element of a Microcor probe is measured to an 18 bit resolution, or 262,144 probe life units. This compares to the 10 bit resolution (1000 divisions) of an ER system. As a result of the proprietary design of the probe and the electronics, the Microcor measurement system is much less sensitive to fluctuations in temperature. The Microcor probes are available in two element forms, flush and cylindrical. Flush probes are suited for pipelines, where pigging may occur, and for bottom-of-line monitoring in oil and gas, or multi-phase flows where typically the corrosive water phase exists. Cylindrical probes with their all-welded construction are suited for more chemically aggressive environments.



**M4700 Flush and M4500 Cylindrical Probes**

Therefore, Microcor offers, for the first time, the ability to make rapid, accurate corrosion rate measurements in any environment. Measurements can be made in conductive or non-conductive liquids, brines, gases, under multiphase conditions, underground, or in concrete. Short-term changes in corrosion rate, which would be undetectable with conventional techniques, are clearly visible using Microcor. This makes the technique ideal for process monitoring, process control, inhibitor evaluation, and cathodic protection studies.

Two software package options are available. The first option is ICMS3 software that provides complete corrosion management, where corrosion rate data can be plotted in real time in parallel with related process variables such as temperature, pressure, pH, dissolved oxygen, inhibitor concentrations etc.

The second option for smaller scale systems is the low cost Microcor Tools Software, which is also available for continuous on-line operation, or for gathering of data from the Microcor data-logging system.



**Microcor Tools Software for smaller scale systems**

The Microcor Transmitter is rated explosion-proof for operation in Class 1 Div 1 to the latest ATEX, UL and CSA standards, and it communicates over an RS 485 Field Bus. This design has the advantage of a more economical field installation cost. A single cable may be used to connect up to 32 transmitters with a single cable run. This single multi-drop cable contains the 24VDC supply to power the transmitters and the RS 485 communication bus. This design avoids the need to run a cable to each transmitter which is required with other designs.

For dedicated on-line systems the RS 485 bus is connected from isolating RS 485 cards mounted directly in the monitoring computer. A separate 24 VDC supply is also required to power the Microcor transmitters. See the figure below.

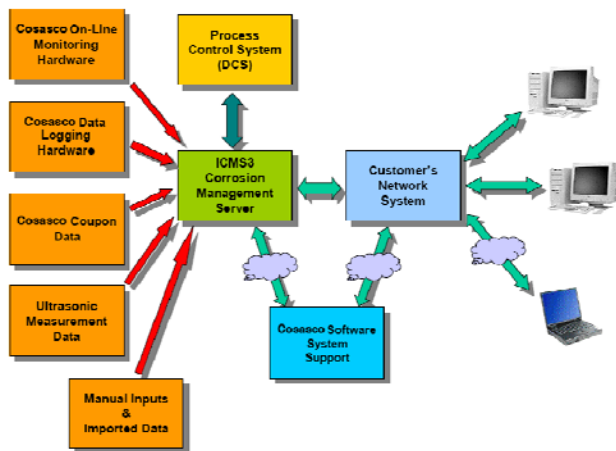

**Complete Integrated Corrosion Management Systems (ICMS3)**

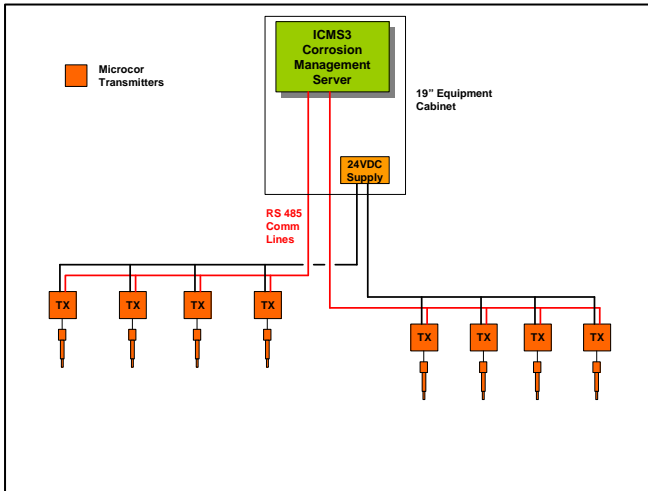

**Typical configuration of ICMS3 Microcor system**

For portable computers or those using the normal serial port on a PC, a small enclosure housing an 115VAC to 24 VDC power supply and an RS 232 to RS 485 isolating converter can be supplied to interface the computer to the field connections. See below.

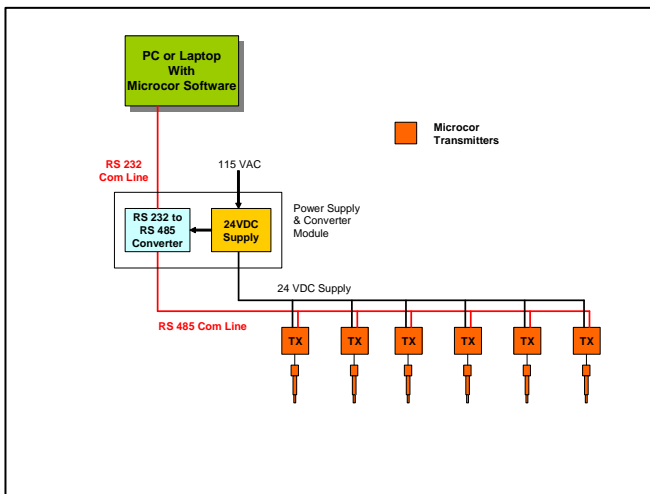

**Typical Configuration of smaller scale Microcor System**

For flexible non on-line systems, the MWT-3905-MDL Data-logger provides remote, battery powered data collection.



**Microcor Data-logger**

Collected data is transferred from the data-logger to the PC with the Checkmate DL intrinsically safe handheld instrument. The Checkmate DL can be used with Microcor Data-loggers and Corrdara RDC's.

## Typical items for a system:

### Microcor probe:

M2500, M2700 Fixed Probes  
M3500, M3700 Retractable Probes  
M4500, M4700 High Pressure (Cosasco) Probes

### Access Fittings:

Fixed Probes - None Required  
Retractable Probes – PN 061560-XX Access  
valve assembly (XX=pipe dia)  
High Pressure Cosasco (see data sheets)

### Connecting Adapter (Probe to Transmitter)

PN 745092 Fixed/Retractable  
PN 745093 High Pressure (For permanent  
connection at 2500 psi max.)  
PN 745093H Hydraulic High Pressure (For permanent  
connection at 2500 psi max.)  
PN 745114 High Pressure (For permanent  
connection at 10,000 psi max.  
when used with pressure retaining  
cover PN 740095)  
PN 745114H Microcor Hydraulic High Pressure Probe  
Adapter 10,000 PSI

### Microcor Transmitter:

MT9485A Microcor Transmitter

### Transmitter Connection cable:

PN 748197-L Flexible Ex-proof connection (USA/CSA)  
PN 748201-L Flexible connection (ATEX)

### Local Junction Box (for connection cable):

PN 702170 Hazardous area junction box

### Data-Logging:

MWT-3905-MDL-0 (Aluminum)  
MWT-3905-MDL-1 (Stainless Steel)

### Data Transfer Unit:

Corrdata Checkmate DL

### PC Power & Interface Module:

PN 748419 RS232/485 converter & 24VDC supply

### Microcor Software:

MS9000A Microcor Tools Software

### ICMS3 Corrosion Management System:

Contact Cosasco for your system requirements

## Hazardous Area Certifications:

### Microcor Transmitter:

#### European

CE: Complies with EMC Directive 89/336/EEC  
ATEX: Complies with ATEX Directive 94/9/EC  
EEx d IIC T6 at  $T_{amb} = -40^{\circ}\text{C}$  to  $+70^{\circ}\text{C}$

#### USA/Canada

UL/ULc Class 1, Zone 1, Ex and AEx d IIC T6  
(UL/ULc Class 1, Div 2, Group A, B, C, D, T6)  
at  $T_{amb} = -40^{\circ}\text{C}$  to  $+70^{\circ}\text{C}$

### Microcor Data-logger:

#### ▪ Data-logger

#### ATEX Certification

Ex d [ib] Class I, Zone 1, IIC, T4,  $T_a = -40^{\circ}\text{C}$  to  $+70^{\circ}\text{C}$

#### North American Certifications

FM AEx d [ib] Class I, Zone 1, IIC, T4,  $T_a = -40^{\circ}\text{C}$  to  $+70^{\circ}\text{C}$   
FMc Ex d [ib] Class I, Zone 1, IIC, T4,  $T_a = -40^{\circ}\text{C}$  to  $+70^{\circ}\text{C}$

#### IEC Ex Certification

IEC Ex d [ib], Class I, Zone 1, IIC, T4,  $T_a = -40^{\circ}\text{C}$  to  $+70^{\circ}\text{C}$

All certifications based on IP66 Enclosure and for use only with  
Power Module P/N 748400

### Data Transfer Unit:

#### Model CHECKMATE-DL-1-Y: Class 1, Zone 1

##### North America:

UL AEx ib IIC T4  $T_{amb} = -20^{\circ}\text{C}$  to  $+50^{\circ}\text{C}$   
ULc Ex ib IIC T4  $T_{amb} = -20^{\circ}\text{C}$  to  $+50^{\circ}\text{C}$

##### Europe:

CE compliant (EMC, ATEX)  
ATEX EEx ib IIC T4  $T_{amb} = -20^{\circ}\text{C}$  to  $+50^{\circ}\text{C}$

##### Australia:

Conformity assessment document is  
available for Australia.

## Cosasco

11841 Smith Avenue  
Santa Fe Springs, CA 90670, USA  
Tel: 1-562-949-0123  
Email: [sales@cosasco.com](mailto:sales@cosasco.com)  
Web Site: [www.cosasco.com](http://www.cosasco.com)

©Rohrbach Cosasco Systems, Inc. All rights reserved

The contents of this publication are presented for information purposes only, and while effort has been made to ensure their accuracy, they are not to be construed as warranties or guarantees, express or implied, regarding the products or services described wherein or their use or applicability. We reserve the right to modify or improve the designs or specifications of our products at any time without notice.

