

Model RSL COSASCO[®] Two-Inch System Retriever Kit

Specifications:

- **Pressure Rating:**
 - Two Models Available:**
 - 2500 PSI (17.2 MPa)
 - 6000 PSI (41.3 MPa)
- **Temperature Rating:**
 - -15°F - 400°F
(-26°C - 204°C)
- **Short Length – Non-Telescoping Design.**
- **Compatible with industry standard COSASCO access fittings.**
- **Lightweight and easy to use.**
- **Meets NACE MR0175 and MR0103**
- **Self-contained. No hydraulics required.**

The Rohrback Cosasco Systems RSL Retriever is the newest innovation from the leader in high pressure access equipment. This precision tool allows safe, easy insertion and removal of various equipment and tools through the industry-standard Rohrback Cosasco Systems Access Fitting – while the pipeline or vessel is under pressure. Used in conjunction with the Rohrback Cosasco Systems Service Valve, system pressure is safely ported into the tool which allows the valve to be opened

and the retrieval operation to be performed. Rotation and translation in and out of the fitting is controlled by two adjustable handles. No movement or telescoping of the tool body is necessary and best of all, no hydraulic

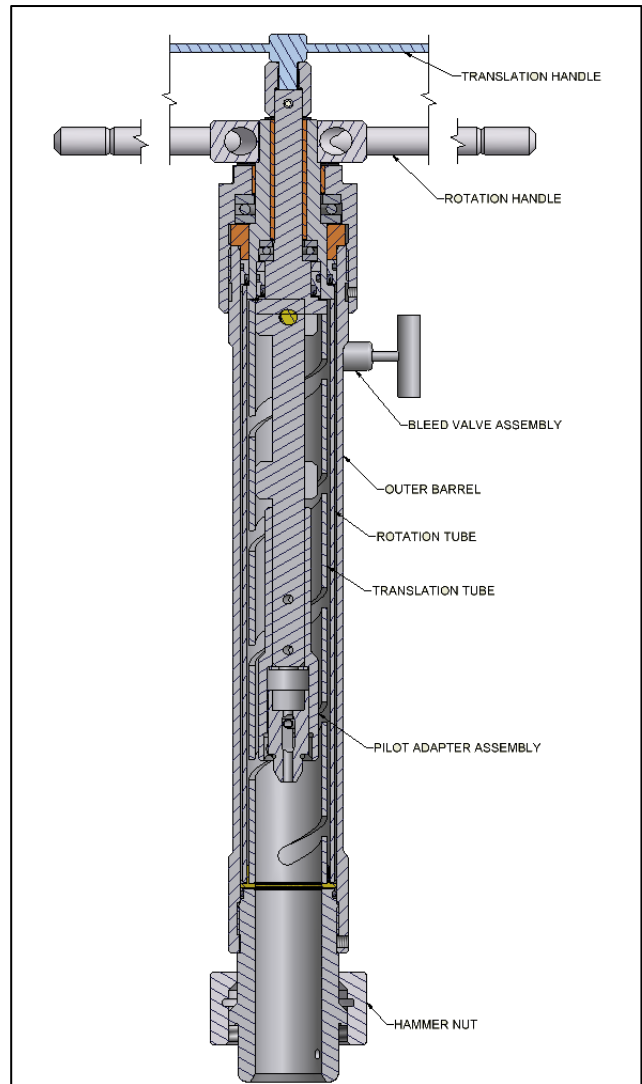

pumps or hoses are required. This tool can be used with the industry-standard Rohrback Cosasco Systems access fitting and service valves, with no adapters required.

Each RSL Retriever Kit is furnished with service tools and spare parts in a sturdy field service box to provide compact, easy storage and portability.

Standard RSL Retriever Kits with standard stroke lengths and temperature ratings are indicated. Special stroke lengths and temperature ratings are available on a special order basis. Please contact Rohrback Cosasco Systems for information.

Description (See Illustration)	Stroke Length		
	18"	25"	37"
A) Retriever Length	33.50"	40.50"	52.50"
B) Removal Clearance	3600# S/V	41.75"	48.75"
	6000# S/V	44.75"	51.75"
Retriever Assembly Weight (Lbs.) (2500 psi rated retriever)	50	57	69
Retriever Assembly Weight (Lbs.) (6000 psi rated retriever)	55	63	76
Retriever Kit Weight (Lbs.) (2500 psi rated retriever)	95	110	125
Retriever Kit Weight (Lbs.) (6000 psi rated retriever)	100	116	132
Retriever Kit Volume (Cu. Ft.)	2.3	2.6	3.3

Stroke	Plug Type	C) Maximum Device Length	
		3600# S/V (7.06" face-to-face)	6000# S/V (10.00" face-to-face)
18"	Solid	9.00"	6.00"
	Hollow	7.50"	4.50"
25"	Solid	16.00"	13.00"
	Hollow	14.50"	11.50"
37"	Solid	28.00"	25.00"
	Hollow	26.50"	23.50"

HOW TO ORDER:

Sizing of retrievers is governed by the length of the stroke required. The stroke length required is based on the size of the service valve, and the size of the longest device that will be retrieved with the tool. Please see the above chart for the maximum device lengths for each stroke length tool, and order the smallest tool which will accommodate the largest device length.

The model RSL retriever is available with two pressure ratings: 2500 PSI or 6000 PSI. The lower pressure tool has the advantage of lighter weight.

ORDERING INFORMATION:

RSL-XXXX-LL	Retriever Kit
	Optional & Spare Parts
600020-XXXX-LL	Retriever Assembly
127500	Socket Adapter Assembly
125137	Brass Hammer
125111	Thread Tap
123672	Surge Tube Assembly
124669	Diverter Hose Assembly – 10 ft.
203855	Backpressure Service Tool
741015	Repair Kit
741012	Seal Kit

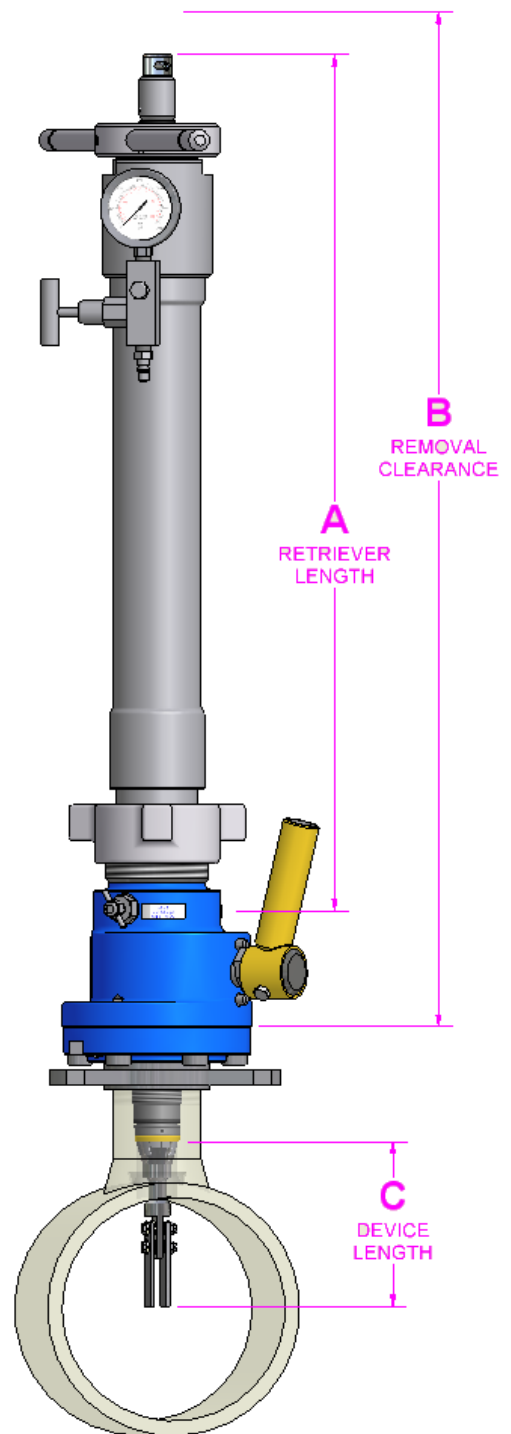

Note:
 XXX = Pressure Rating (2500 or 6000)
 LL = Stroke Length (18, 25, or 37)



Rohrback Cosasco Systems, Inc.
 11841 East Smith Avenue
 Santa Fe Springs, CA 90670, USA
 Tel: (1) 562-949-0123 Fax: (1) 562-949-3065
 US Toll Free: 800-635-6898
 E-Mail: sales@cosasco.com
 Web Site: www.cosasco.com

