

MODEL 3000/3000G
RETRACTABLE CORROSOMETER PROBE
USER MANUAL

ROHRBACK COSASCO SYSTEMS, INC.
11841 E. SMITH AVENUE
SANTA FE SPRINGS, CA 90670
TEL: (562) 949-0123
FAX: (562) 949-3065

3000-MANUAL

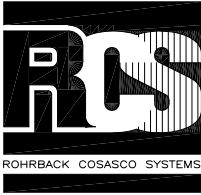

ROHRBACK COSASCO SYSTEMS, INC.

11841 E. SMITH AVENUE
 SANTA FE SPRINGS, CA 90670
 TEL: +1-562-949-0123
 WWW.COSASCO.COM



ISO 9001:2000
 Certificate No. FM 10694

RETRACTABLE CORROSOMETER
CORROSION PROBES
MODELS 3000 & 3000G LOOP ELEMENT

Maximum Pressure: 1,000 PSI (Safety clamps and retractor are required for pressure above 150 PSI).

Maximum Temperature: 500°F (260°C) (Safety Clamps and retractor are required for temperatures above 150°F [65°C]).

PROBE LENGTH			
ORDER LENGTH	A DIM.*		B DIM. ±1/4
	MAX.	MIN.	
18.0 (457mm)	15.20 (386mm)	2.0 (51mm)	23.44 (595mm)
24.0 (610mm)	21.20 (538mm)	2.0 (51mm)	29.44 (747mm)
30.0 (762mm)	27.20 (690mm)	2.0 (51mm)	35.44 (900mm)
36.0 (914mm)	33.20 (843mm)	2.0 (51mm)	41.44 (1052mm)
42.0 (1067mm)	39.20 (995mm)	2.0 (51mm)	47.44 (1205mm)

* "A" Dimension is maximum reach.

- A. Disc, I.D.
- B. Gasket, Dust Cap
- C. Cap, Dust
- D. Fitting, Seal Loading (1 5/16" Hex)
- E. Insert, Replacement Assembly
- F. Teflon "O" Ring
- G. Body, Housing (1 1/16" Hex)
- H. Nut, Locking (1" Hex)
- I. Ferrule, Rear
- J. Ferrule, Front
- K. Nut, Stuffing (1 1/2" Hex)
- L. Gland, Rear
- M. Material, Packing
- N. Gland, Front
- P. Body, Stuffing Box (1 3/4" Hex)
- Q. Shield
- R. Safety Wire

** INSTALL SAFETY WIRE (R) PROVIDED THROUGH STUFFING NUT (K) AND TWIST WIRE CLOCKWISE AT 90° TO EACH OTHER UNTIL REACHING FURTHER CLOCKWISE HOLE IN STUFFING BOX BODY (P); PULL TIGHT AND CONTINUE TWISTING FOR 3/4"; THEN CLIP END AND PIGTAIL.

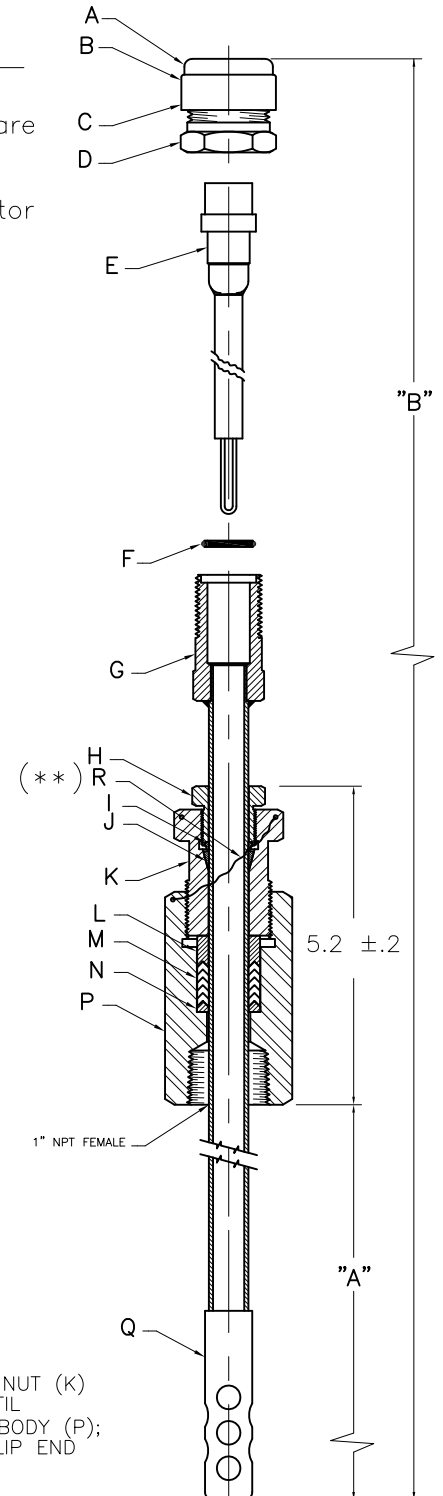

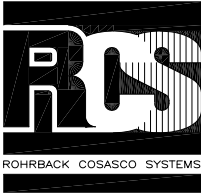

ROHRBACK COSASCO SYSTEMS, INC.

11841 E. SMITH AVENUE
 SANTA FE SPRINGS, CA 90670
 TEL: +1-562-949-0123
 WWW.COSASCO.COM



ISO 9001:2000
 Certificate No. FM 10694

SAFETY CLAMP ASSY. INSTALLATION
RETRACTABLE CORROSOMETER® AND CORRATER®
CORROSION PROBES AND COUPON HOLDERS

NOTE: This kit is intended for installation on probes removed from service. Read ALL instructions carefully and completely before starting. The 3/8" diameter threaded rods on the safety clamp assembly must be sized prior to using the Retractor, to allow sufficient mounting clearance. Any rod in excess of 1" past either end of the safety clamp jam nuts, at position of desired insertion, must be cut off.

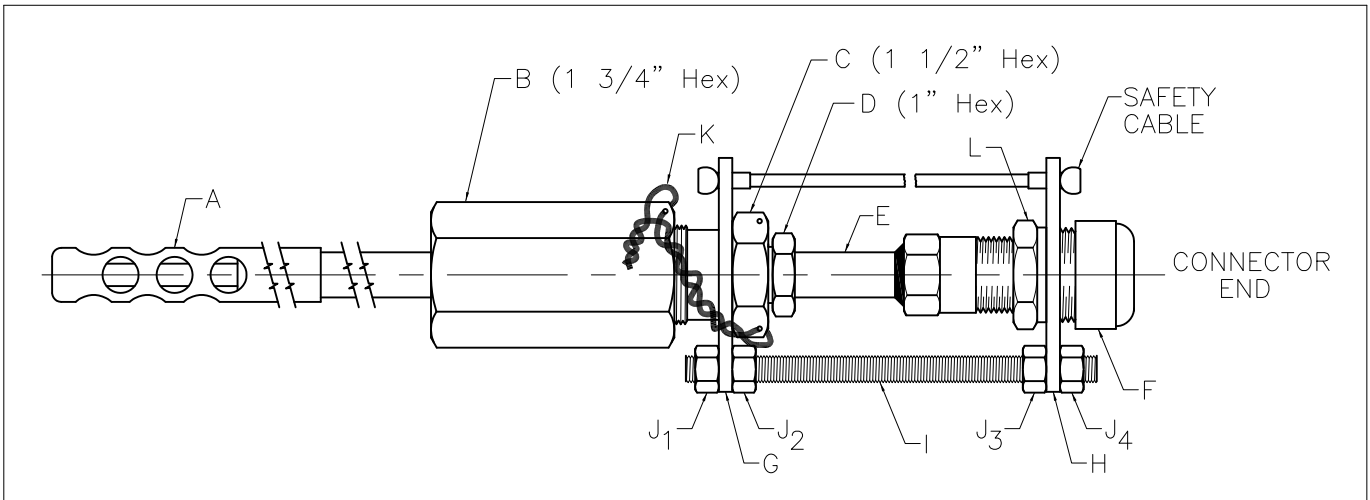

TYPE "A" CONNECTOR (1" NPT)

- | | | |
|----------------------|----------------------------|-------------------------|
| A. Shield | E. Probe Assembly | I. Threaded Rod (2) |
| B. Stuffing Box Body | F. Dust Cap | J. Jam Nuts (1,2,3,4) |
| C. Stuffing Nut | G. Safety Flange, Inboard | K. Safety Wire |
| D. Locking Nut | H. Safety Flange, Outboard | L. Seal Loading Fitting |

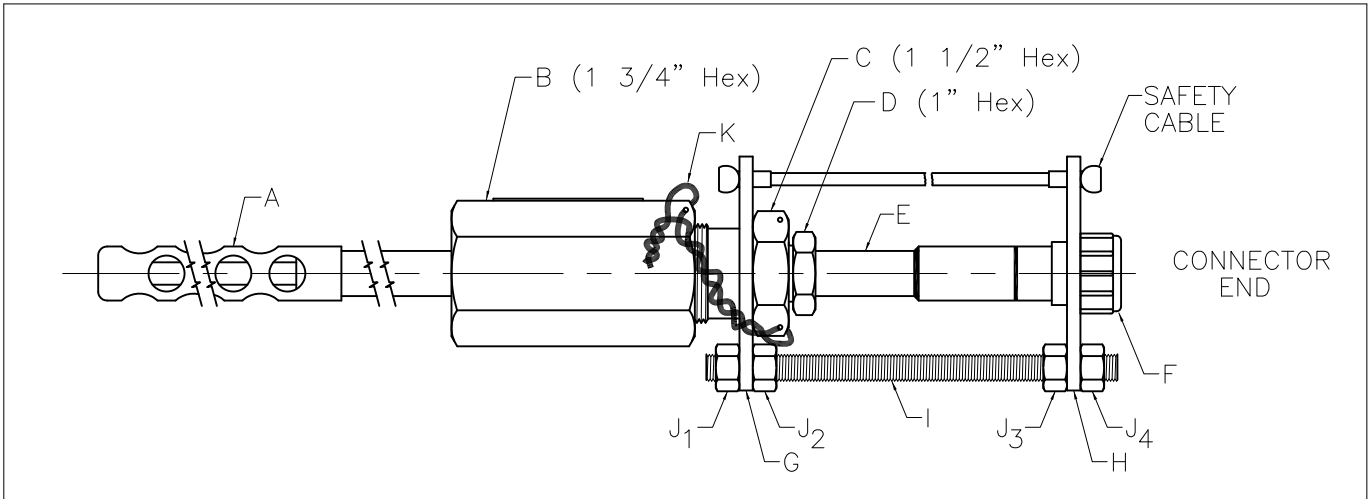

TYPE "B" CONNECTOR (7/8-20 UNEF)

- | | | |
|----------------------|----------------------------|-----------------------|
| A. Shield | E. Probe Assembly | I. Threaded Rod (2) |
| B. Stuffing Box Body | F. Dust Cap | J. Jam Nuts (1,2,3,4) |
| C. Stuffing Nut | G. Safety Flange, Inboard | K. Safety Wire |
| D. Locking Nut | H. Safety Flange, Outboard | |

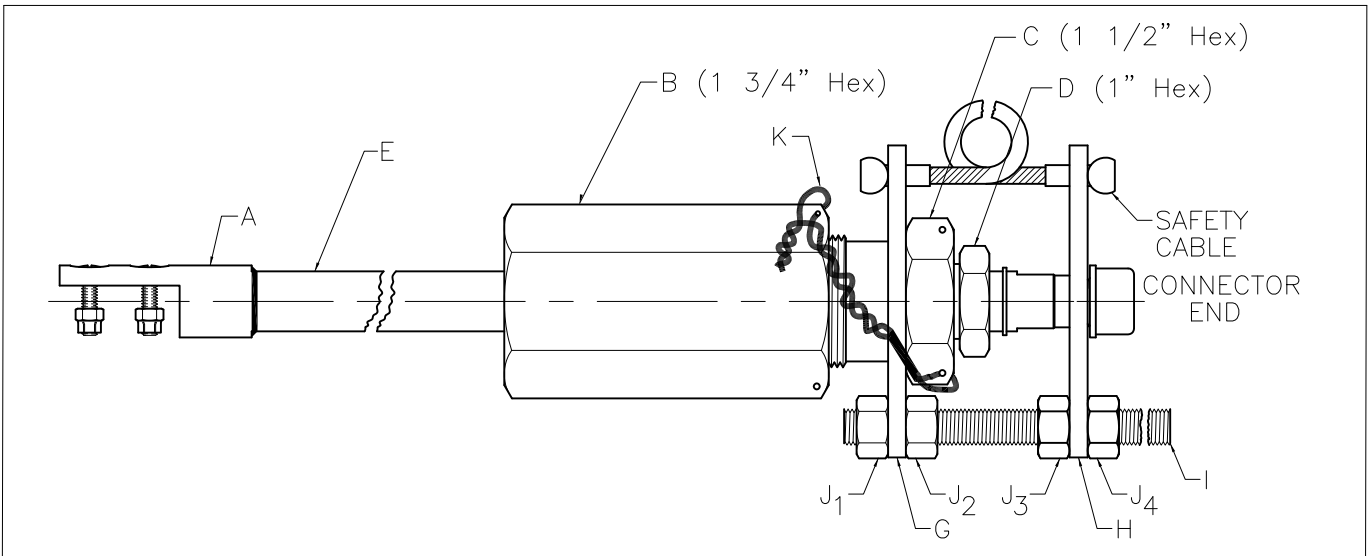

3/4"NPT CONNECTOR

- | | | |
|----------------------|----------------------------|-----------------------|
| A. Holder, Coupon | E. Probe Assembly | I. Threaded Rod (2) |
| B. Stuffing Box Body | F. Dust Cap | J. Jam Nuts (1,2,3,4) |
| C. Stuffing Nut | G. Safety Flange, Inboard | K. Safety Wire |
| D. Locking Nut | H. Safety Flange, Outboard | |

(2)

WARNING: DO NOT LOOSEN ANY PROBE ASSEMBLY NUTS WHILE PROBE IS
IN SERVICE (UNDER PRESSURE).

1. Remove Dust Cap Assembly (F) and thread Outboard Safety Flange (H) onto the Connector. Replace Dust Cap Assembly (F).
2. Unscrew Stuffing Nut (C) from Stuffing Box Body (B) and separate an inch or more.
3. Install Inboard Safety Flange (G) in gap between Stuffing Nut (C) and Stuffing Box Body (B), and slide Flange past threads of Stuffing Nut (C). Thread Stuffing Nut (C) into Stuffing Box Body (B).
4. Thread two Jam Nuts (J_2 and J_3) onto the middle of each Threaded Rod (I); then place Threaded Rods (I) (with Jam Nuts) through holes in Safety Flanges (G and H).
5. Place Jam Nuts (J_1 and J_4) onto Threaded Rods (I) on the outside of the Outboard Safety Flange (H) and the outside of the Inboard Safety Flange (G). Push Flanges (G and H) toward each other and tighten tighten outside Jam Nuts (J_1 and J_4); then tighten inside Jam Nuts (J_2 and J_3) flush with inside of Inboard and Outboard Safety Flanges.
6. Install Safety Wire (K) provided through Stuffing Nut (C) and twist wire clockwise at 90° to each other until reaching further clockwise hole in Stuffing Box Body (B); pull tight and continue twisting for 3/4"; then clip end and Pigtail.



ROHRBACK COSASCO SYSTEMS
11841 East Smith Avenue
Santa Fe Springs, CA 90670
Tel: (562) 949-0123 Fax: (562) 949-3065
www.rohrbackcosasco.com



ISO 9001:2000
Certificate No. FM 10694

INSTRUCTIONS FOR INSTALLATION OF RETRACTABLE PROBE WITHOUT THE PROBE RETRACTOR

IMPORTANT: Use extreme care in handling the probe to prevent damage to the measuring element. Do not touch the measuring element with the fingers or allow any foreign material such as grease or oil to come in contact with it before installation.

READ ALL INSTRUCTIONS CAREFULLY AND COMPLETELY BEFORE ATTEMPTING PROBE INSERTION. IN EXCESS OF 150 PSI OF VESSEL PRESSURE AND /OR 150 °F TEMPERATURE, MECHANICAL ASSISTANCE IS REQUIRED. (USE ROHRBACK COSASCO SYSTEMS P/N 603000 PROBE RETRACTOR AND APPROPRIATE SAFETY CLAMP). IF RETRACTOR IS USED, THESE INSTRUCTIONS ARE SUPERCEDED BY THE RETRACTOR MANUAL.

CAUTION: NEVER STAND DIRECTLY BEHIND A PROBE IN SERVICE WHICH HAS A SAFETY CLAMP REMOVED OR ON WHICH THE LOCKING NUT IS LOOSENED, UNLESS SUFFICIENT BACK PRESSURE IS MAINTAINED ON THE PROBE. ALL PERSONNEL SHOULD BE FAMILIAR WITH THE PROPER PROCEDURE FOR PROBE INSERTION AND REMOVAL, AND ADEQUATE SAFETY GEAR SHOULD BE WORN CONSIDERING THE PROCESS FLUID INVOLVED.

A. INSTALLATION:

1. Assemble the access valve and nipples. A 1" female NPT connection is provided on the Stuffing Box Body, to mate with the thread on the valve outlet nipple.
2. Close the valve. The vessel may now be pressurized, if desired.
3. If a safety clamp kit has been installed, remove the outer two jam nuts closest to the probe connector end.
4. Loosen the Locking Nut and Stuffing Nut, BUT DO NOT REMOVE!
5. Slip the Stuffing Box assembly as far forward (toward the Shield/measuring element) as possible.
6. Apply thread sealing compound to the threads of the valve outlet nipple.
7. Mount the probe onto the outlet valve nipple and tighten 2-3/4 to 3-1/4 full turns past hand tight. (Normal thread engagement to make a tight joint is 0.66").
8. Tighten the Stuffing Nut HAND TIGHT.
9. While maintaining counter pressure on the probe connector end, open the valve slowly to equalize pressure in the assembly.
10. Insert the probe to the desired orientation and penetration.
11. While continuing to maintain counter pressure, tighten the Locking Nut 3/4 turn past HAND TIGHT.
12. While continuing to maintain counter pressure, tighten the Stuffing Nut 1/2 turn past HAND TIGHT.
13. See instructions supplied with the probe assembly and/or the safety clamp kit for SAFETY CLAMP and Safety Wire Installation instructions, if required.

P/N 006193 REV. E



ROHRBACK COSASCO SYSTEMS
11841 East Smith Avenue
Santa Fe Springs, CA 90670
Tel: (562) 949-0123 Fax: (562) 949-3065
www.rohrbackcosasco.com



ISO 9001:2000
Certificate No. FM 10694

INSTRUCTIONS FOR INSTALLATION OF RETRACTABLE PROBE WITHOUT THE PROBE RETRACTOR

14. Once safety clamps have been installed, or all fittings have been tightened, counter pressure can be released.
15. Check all fittings for leaks and tighten as necessary. Do not over tighten the Stuffing Nut, as this may damage the packings.

B. REMOVAL

1. Apply counter pressure to the probe connector end before loosening any fittings.
2. If a safety clamp kit has been installed on the probe, remove the outer two jam nuts closest to the probe connector end.
3. Remove Safety Wire, if present.
4. Loosen the Locking Nut until it can be turned freely. Gradually loosen the Stuffing Nut until the probe can be moved out slowly.
5. Allow the probe to retract until either the Shield contacts the bottom of the Stuffing Box Assembly or the safety cable is fully extended.
6. When the probe is extracted, close the valve. Failure to extract probe fully before closing valve will result in damage to the probe and valve.
7. Using caution, slowly unscrew the Stuffing Box assembly 2-3/4 to 3-1/4 turns from the valve outlet nipple to allow residual pressure to bleed off. Once all residual pressure is completely eliminated, the Stuffing Box assembly may be removed from the valve outlet nipple.

P/N 006193 REV. E