

Microcor[®] Online System



Model MT-9485A Transmitter



Probe Adapters

Features:

- **High Resolution Corrosion Measurement**
- **Rapid Response**
- **Online or Data-logging Configurations**
- **Rated for Hostile Environments**
- **Approved for Hazardous Locations**

The Microcor[®] corrosion monitoring technology has been developed to substantially increase the speed of response over conventional monitoring techniques, such as coupons, electrical resistance (ER) probes, approaches that of linear polarization resistance (LPR), and is functional in all environments.

Microcor is the result of patented technology which combines the rapid response of LPR and the universal applicability of ER.

The Microcor Transmitter is rated explosion-proof to the latest ATEX, UL and CSA standards, and it communicates over an RS 485 Field Bus. This design has the advantage of a more economical field

installation cost. A single cable may be used to connect up to 32 transmitters with a single cable run. This single multi-drop cable contains the 24 VDC supply to power the transmitters and the RS 485 communication bus. This design avoids the need to run a cable to each transmitter which is required with other designs.

For dedicated on-line systems the RS 485 bus is connected from isolating RS 485 cards mounted directly in the monitoring computer. A separate 24 VDC supply is also required to power the Microcor transmitters.

Specifications:

Transmitter Model MT-9485A

- **Resolution:** 18 bit (1 part in 262,144)
- **Probe element resistance range:** 1 to 50 milliohms
- **Power supply:** 10-32 VDC at the transmitter
- **Current consumption:** at 24VDC typical 17 mA
- **Communication:** RS 485 two-wire 2400 Baud, 8 data bits, 1 stop bit, no parity (300 baud when connecting through -RS232/485 converter MA-1000)
- RS 485 addresses 0 to 31
- **Ambient temperature range:** -40C to +70C (-40F to +158F)
- **Enclosure:** NEMA 7 and IP 66/ NEMA 4X
- **Weight:** 3.5 lbs (1.6 Kg)
- **Hazardous area Certifications:**
 - Europe (CE/ATEX/EMC)
 - CE 0539 II 2G
 - DEMKO 03 ATEX 0215219
 - STD EEx d IIC T6
 - T_{amb}= -40C to +70C

USA/Canada



Class I, Zone 1, AEx d IIC T6/EX d IIC T6
 Class I, Div 1, Groups A, B, C, D
 when installed in accordance with installation drawing 702106
 T_{amb}= -40C to +70C

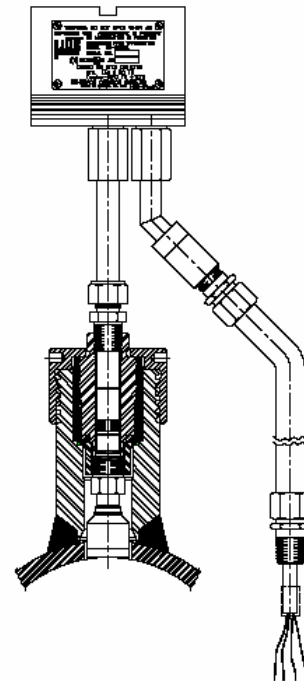

Microcor Transmitter on an Access Fitting

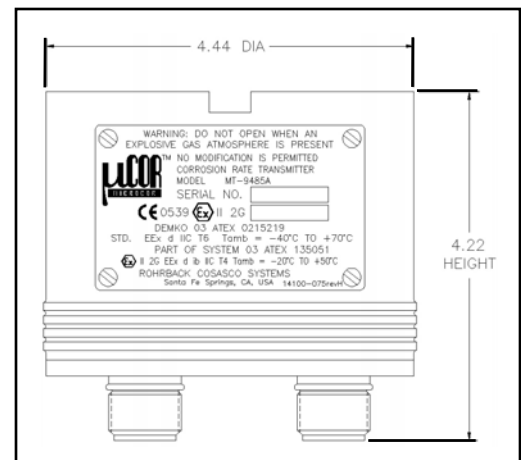

Ordering Information:

Transmitter:

P/N MT-9485A – Microcor Transmitter, RS-485

Probe to Transmitter:

- P/N 745092 – Probe Adapter for M2000 and M3000 series Fixed and Retractable Probes
- P/N 745093 – Probe Adapter for M4000 series High Pressure (Cosasco®) Probes
- P/N 748223-6 – Probe to Transmitter Cable Assembly (UL/CSA)
- P/N 748224-6 – Probe to Transmitter Cable Assembly (ATEX)



Rohrback Cosasco Systems, Inc.
 11841 East Smith Avenue
 Santa Fe Springs, CA 90670, USA
 Tel: (1) 562-949-0123 Fax: (1) 562-949-3065
 US Toll Free: 800-635-6898
 E-Mail: sales@cosasco.com
 Web Site: www.cosasco.com



ISO 9001:2008
 Certificate No. FM 10694