

# Model ICMS<sup>3</sup><sup>TM</sup> Integrated Corrosion Management System

## *Features:*

- ***Total Corrosion Data Management***
- ***Data Exchange with DCS/PCS/SCADA Systems***
- ***Correlate Corrosion & Process Data***
- ***Enables Highly Cost-Effective Asset Management***
- ***Designed Specifically for Corrosion Management Personnel***
- ***Full Client-Server Operation***

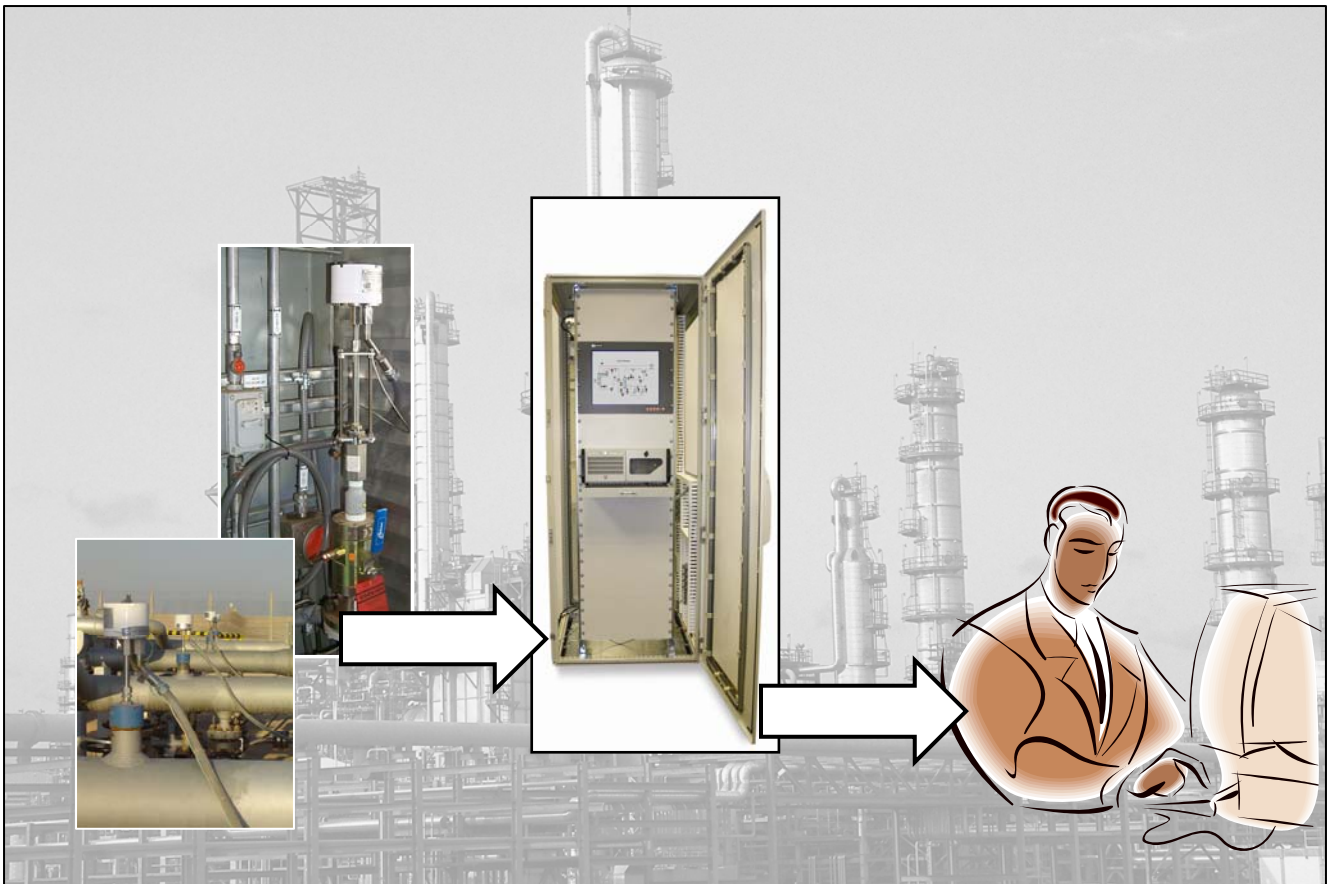

The ICMS3 Integrated Corrosion and Erosion Management System is the most comprehensive and powerful on-line system available. It is ideally suited for medium to large scale systems, or for small systems with the need for future growth. The ICMS3 Integrated Corrosion and Erosion Management System allows integration of all the RCS range of corrosion, erosion, and cathodic protection monitoring inputs, including the latest in metal loss Microcor® technology, Corraterr corrosion rate, pitting tendency

and galvanic probe transmitters. With the varying range of applications, communication and network infrastructure, no two ICMS3 systems are alike. The simple flexibility of the ICMS3 systems allows different configurations to be easily designed and implemented to meet your specific requirements. The combination of RCS field-proven hardware, Amulet software engine, and the extensive systems experience of our RCS engineers, assures customization to your specific requirements and guaranteed performance.

---

## ICMS3 SYSTEM OVERVIEW

The ICMS3 system corrosion management server is the heart of the corrosion or erosion monitoring system, integrating several forms of corrosion monitoring and process data into one complete online system. Corrosion and erosion monitoring is managed as a process parameter with constant streaming data directly into your preferred system interface.

According to the application, RCS will typically incorporate one of several different types of corrosion and erosion monitoring system components, and operate over various communication links. For example, an upstream oil and gas production field will vary from a refinery or offshore platform both in the monitoring technologies employed and the communication infrastructure used. An upstream oil and gas field is spread over large distances with operation through an existing communication network where the ICMS3 system must be integrated into this existing network. By comparison, a Refinery, Gas Plant, or offshore platform will have shorter direct communications links using wired, wireless, or fiber optic connections. The unmatched range of monitoring technologies offered by RCS allows the proper matching of the system to the application.

The overall ICMS3 system architecture comprises the following:

1. On-line Monitoring Hardware
  - a. Microcor® Digital High Resolution
  - b. Corratel® Digital LPR
  - c. Quicksand® Digital Erosion
  - d. Corrosometer® Analog
  - e. Corratel Analog
  - f. Cord-Com™ Cathodic Protection
  - g. Any other Related Analog Inputs
2. Datalogging Hardware
3. Metal Loss Coupons
5. Ultrasonic Measurement Data
6. Manual Inputs and Imported Data
7. ICMS3-Amulet Software
8. Client Server Operation over Network
9. Customer VPN Client Operation
10. RCS VPN or Modem Remote Support

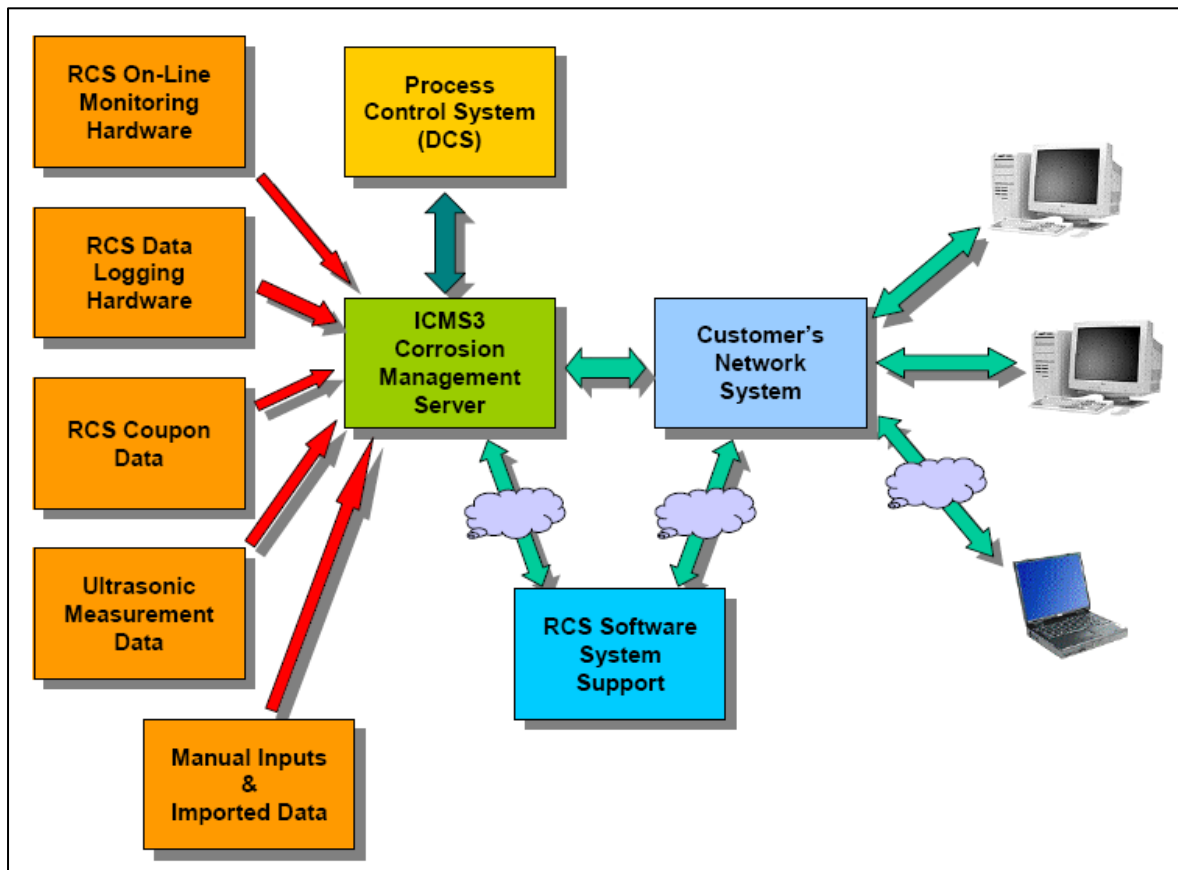

## ON-LINE DIGITAL SYSTEMS

### Microcor High Resolution Metal Loss

Microcor advanced Digital Metal Loss technology is perfectly complemented by the ICMS3 on-line system. Useable in any process environment, it provides 50 times greater sensitivity than existing ER methods, allowing a 10 mpy upset to be detected in about 1 hour instead of 2 days. An example of a simple wired configuration is shown opposite. The explosion-proof Microcor transmitter uses a 24 VDC supply and 2-Wire RS 485 communication bus, allowing connection of up to 32 transmitters in a multi-drop or star configuration. This connection flexibility greatly reduces the cost of field wiring and installation. Microcor digital or Corrosometer analog technology is essential in process fluids, such as hydrocarbon service, where a continuous corrosive water phase is not consistently present at the probe. Corrosion rate is computed from the change of metal loss over time.

### Corrater Corrosion Rate and Pitting

Corrater electrochemical technology is generally preferred for clean water systems (hydrocarbon content less than 5%) as it produces an instantaneous corrosion rate with a single reading. In addition it also has a pitting tendency measurement based on electrochemical current noise. The ICMS3 system, as shown to the right, enables the Microcor and Corrater transmitters (Model E-9020) to be "mixed and matched" as required in the systems using the same communications protocol and wiring system. Both transmitters use a RS-485 multi-drop connection and 24 VDC power supply.

### Quicksand Erosion Monitoring

The Quicksand System utilizes the same high resolution technology as Microcor with a probe specifically designed for sand erosion detection. Often times sand production can cause rapid erosion and wear on the outer diameter of bends and areas downstream of changes in pipeline diameter. The Quicksand (Model ST-9485A) transmitters operate on the same power and communication bus as the Microcor and Corrater digital transmitters.

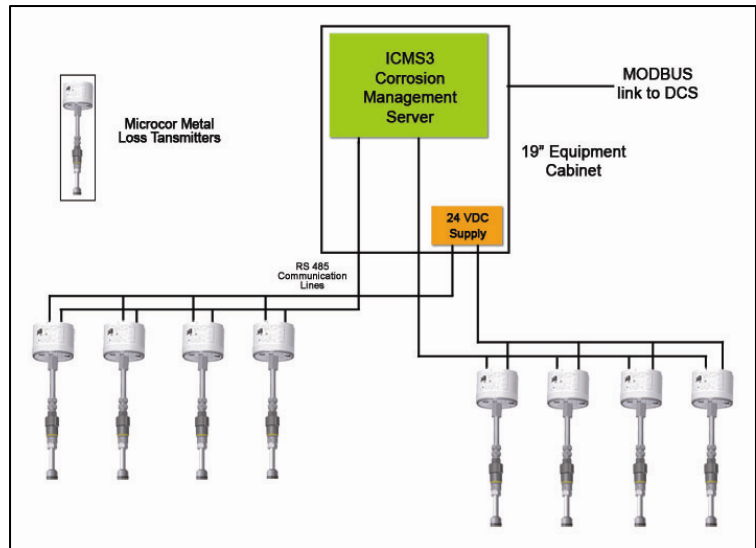

**Simple Wired System with Microcor Transmitters**

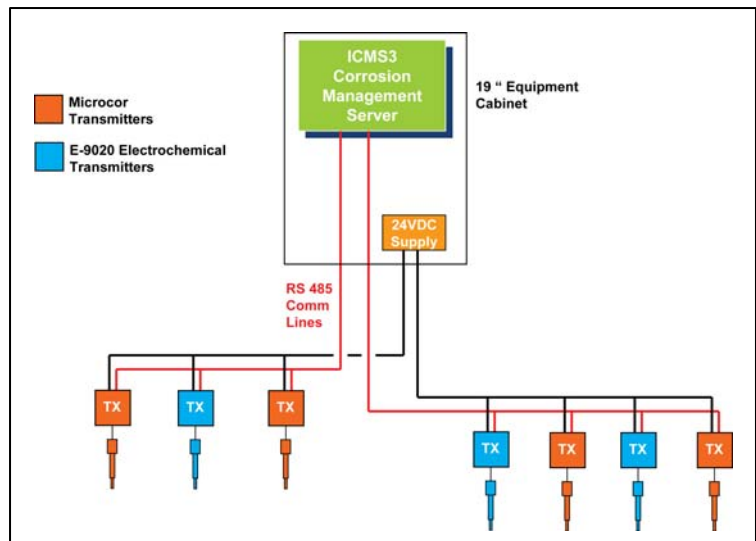

**ICMS3 System shown with Microcor & E-9020 Transmitters**

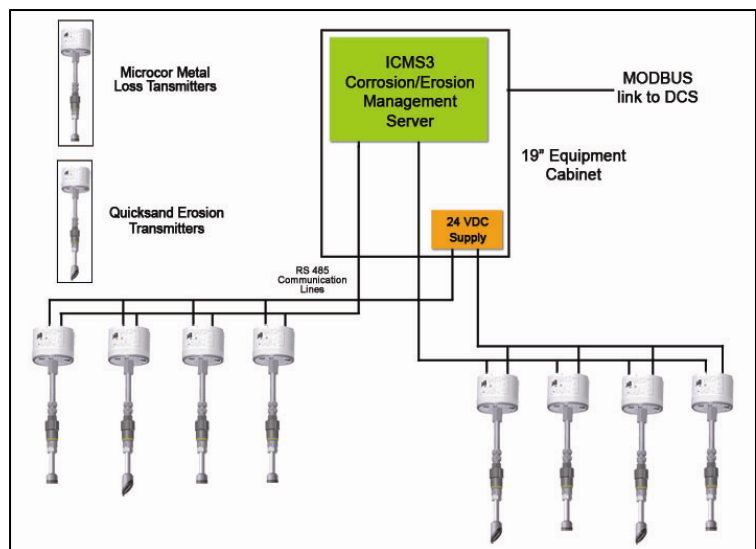

**ICMS3 System shown with Microcor & Quicksand Transmitters**

**Corrosometer and Corratrater PIM's**

Many legacy systems in the field use 4-channel Corrosometer and Corratrater Probe Interface Modules (PIM's). These PIM's have local power and a 4-wire RS 485 digital communication bus. The PIM to probe distance is greater than for the Microcor / Corratrater E9020 system but the Corrosometer is lower resolution than Microcor and the system's hazardous location certifications are more restricted. Both new and legacy systems can operate on the same ICMS3 system, with a separate bus for each type. This can be useful in extending existing systems with the newer technology.

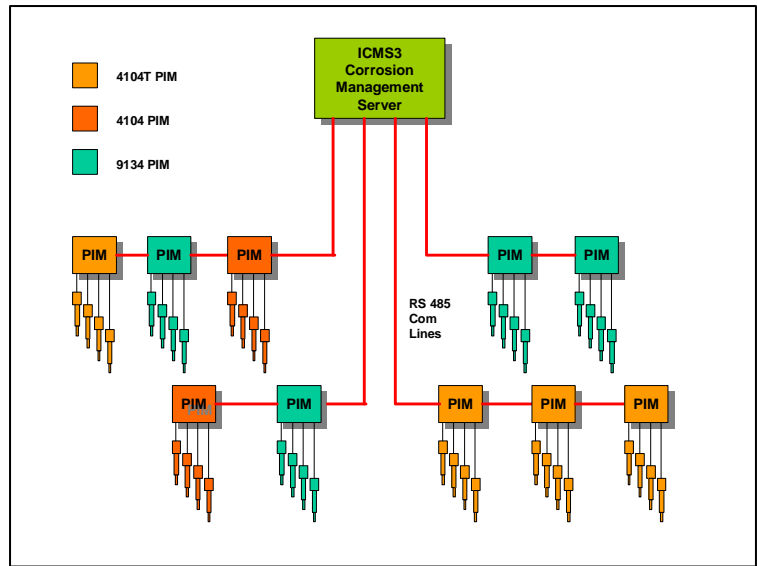

**ICMS3 shown with Probe Interface Modules**

**Wireless Microcor and Corratrater**

New Wireless HART Microcor (MWT) and Corratrater (CWT) transmitters (available early 2009) may also be fed into the ICMS3 system through the Wireless gateway over the Ethernet network, or transported through an existing HART Wireless process control network. Wireless systems are particularly attractive due to their reduced installation costs typically estimated at around \$10,000 per point. The Microcor Wireless transmitter has on-board computation of corrosion rate from metal loss, providing for even easier integration into other wireless process control systems.

On-line high resolution non-intrusive ultrasonic Ultracorr™ wireless (UWT) transmitters are anticipated to be available later in 2009.

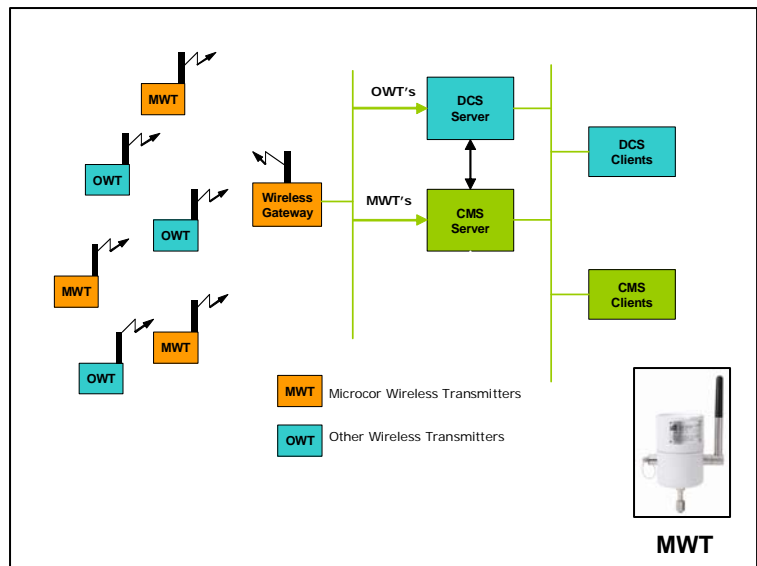

**New Wireless Transmitters can be fed Directly into ICMS3**

**Cathodic Protection Monitoring**

Commonly, the Cathodic Protection system and internal corrosion and erosion mitigation is controlled by the same personnel. With the Cord-Com multi-channel input, CP impressed current rectifiers, sacrificial anodes, and reference electrodes can all be monitored into the same ICMS3 Server over the same network. This enables all of the corrosion related data to be kept in one central database for ease of management, and control by the relevant staff. These systems have been deployed both onshore and offshore, with various communication channels as required by the application and existing communications infrastructure.

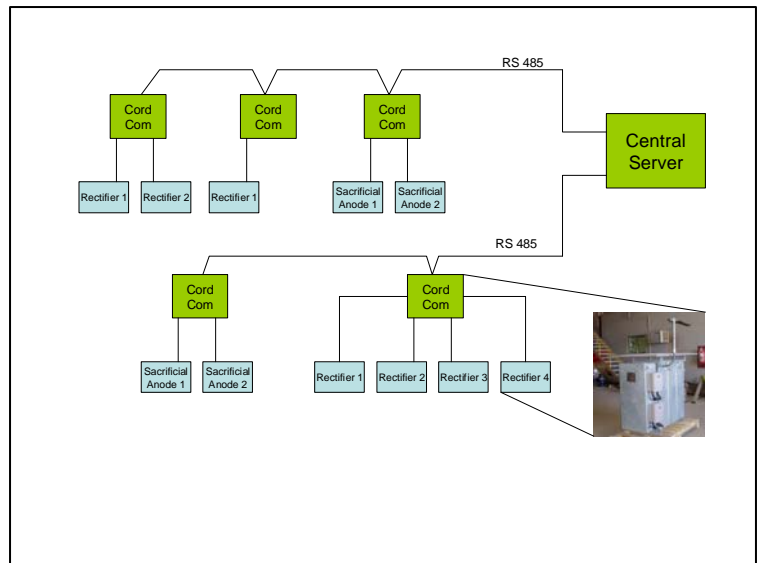

**CORD-COM Remote CP Monitoring with ICMS3**

## ON-LINE ANALOG SYSTEMS

### Corrosometer and Corratr and Others

Legacy systems with 4-20 mA Corrosometer and Corratr Transmitters, or systems that bring in any other 4-20 mA signals to be monitored are easily integrated into the ICMS3 system through analog to digital interface modules. If existing corrosion transmitters or other transmitters are connected to the DCS or SCADA system, these parameters can be transferred to the ICMS3 server through a variety of interface drivers, such as Modbus, PI system drivers or OPC.

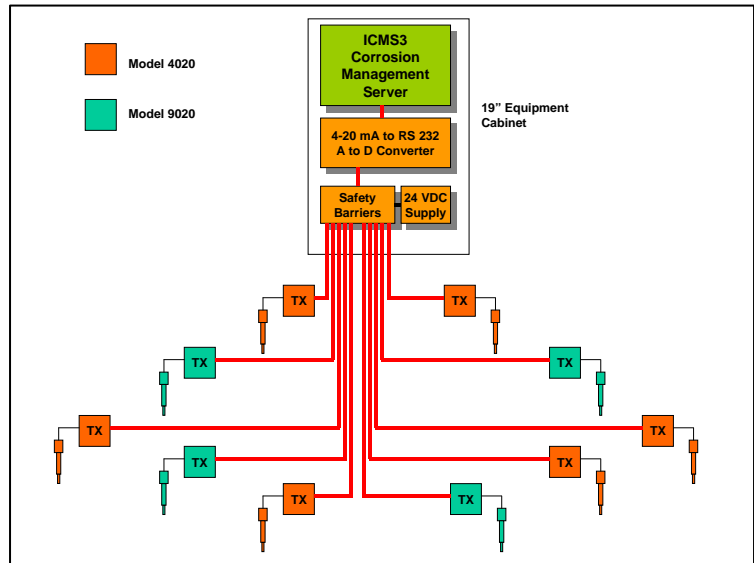

ICMS3 Server shown with Analog to Digital Converter

## DATA LOGGING SYSTEMS

### Corrdata® Data Loggers

ICMS3 systems are assisting an increasing number of corrosion monitoring systems to go fully on-line, often replacing earlier data logging systems. However, additional remote or investigative probe locations may also need monitoring on an on-going or occasional basis. Battery operated Remote Data Collectors are well suited for these locations, and with CheckMate DL or CheckMate Plus instrument this data can be collected and transferred to the ICMS3 System, providing a single location for all of the corrosion data.

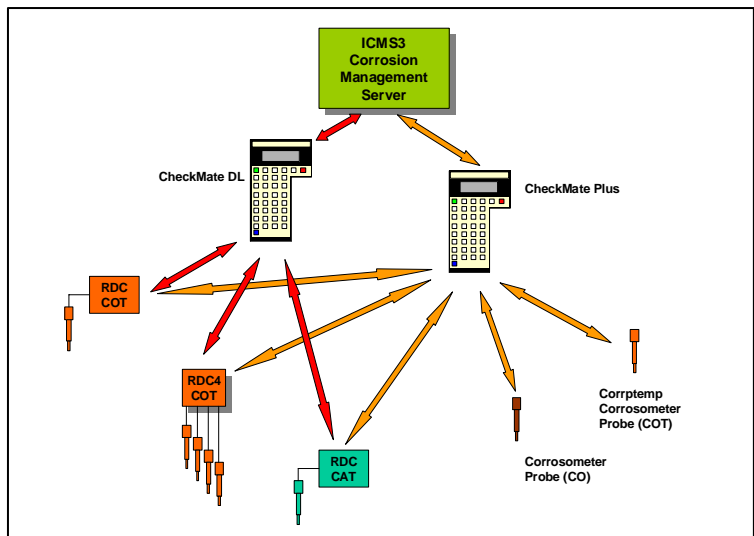

Data can be collected and transferred to the ICMS3 System using Corrdata Data-Loggers

### Ultrasonic Measurement Data

ICMS3-Amulet software supports Ultrasonic inspection data from Krautkramer and Panametrics Units. RCS's on-line Ultracorr system provides an unparalleled accuracy in continuous on-line monitoring offering a resolution of 0.1 mils, approximately 40 times better than normal inspection ultrasonics. It is ideal for buried pipelines where intrusive monitoring is difficult. Ultracorr uses high resolution technology to detect both erosion and corrosion. Multiple transducers are connected to a junction box where the Ultracorr instrument can easily be connected to download periodic time and date stamped measurements of wall thickness. Data can then be transferred directly in from the Ultracorr instrument into the ICMS3 server for analysis and computation of corrosion rates.

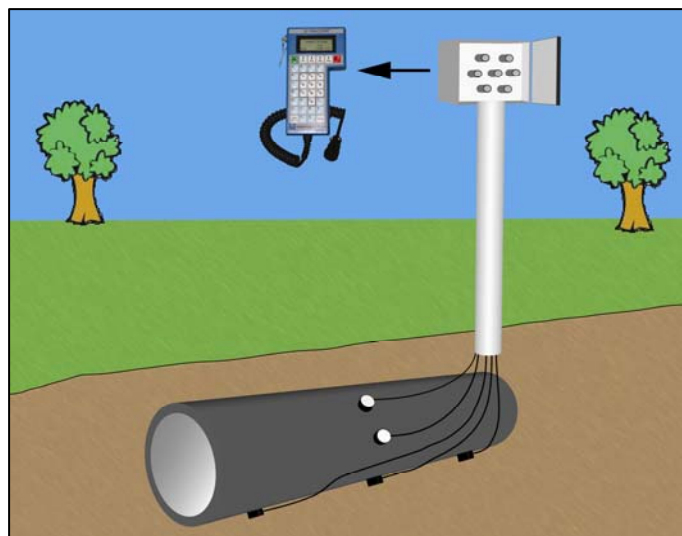

Ultracorr transducers are connected to a junction box at one central location for data collection

## Metal Loss Coupons

Coupon data is one of the simplest forms of corrosion monitoring. Coupon data is used in on-line systems as a calibration standard for other means of corrosion monitoring (ER and LPR). In addition coupons can be examined for evidence of pitting and other localized forms of attack that are not recognized by other on-line monitoring techniques. Coupon monitoring points are strategically located throughout the system. Coupons are then retrieved, weighed, and analyzed at set intervals, usually three months, and entered into the ICMS3 Server for correlation with other corrosion data and process parameters.

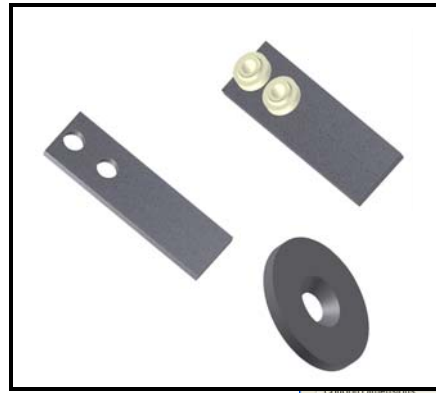

**COSASCO 2" System Coupons**

**ICMS3 Coupon Entry Screen**

## Process Parameters

Probably one of the most important features of the ICMS3 system is the ability to easily correlate corrosion related data with changes in process parameters, other imported data from laboratory analysis, or manually input data such as inhibitor injection rates. Factors affecting corrosion can be quite complex in many applications and require careful analysis to first understand the controlling factors, and then secondly to maintain control. The ICMS3 system is essential to be able to do this effectively and reap the financial rewards.

The DCS Server is optimized for process measurement and control, with rapid response and short history span of 1 or 2 days. Typically process data is made available across the business network through a Process Data Historian. The ICMS3 Server is optimized for the slower but more extensive corrosion related data and analysis. Data exchange between the two servers is usually accomplished through Modbus, OPC, or through a driver to a PI Process Data Historian.

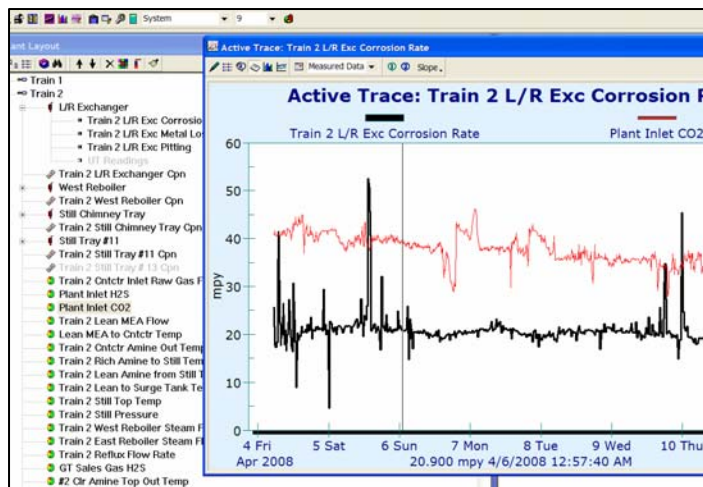

**Metal Loss Graph**

With the present practice of separating the process network from the business network with a firewall to protect the process control system, it is most common for the Corrosion Server to be located on the business network, since the corrosion analysts are normally on the business network, and operators also have access to that network.

Derivative process parameters and Key Performance Indicators (KPI's) can be easily created in the ICMS3 System with the extremely powerful and easy-to-use Calculation Designer, avoiding custom programming. Cost information can be added to the system so that financial parameters can be tracked, such as the cost of inhibitor per barrel and the inhibitor usage to compute the cost of corrosion mitigation.

**Calculation Designer**

## ICMS3-Amulet Software

The Corrosion Monitoring server is commonly mounted in a 19" rack in an equipment room adjacent to the plant central control room along with the DCS and SCADA servers.

The server uses Microsoft SQL Server as its database providing client/server operation to users over the network.

Designed by corrosion engineers for corrosion engineers, the program has extensive capabilities. Some of its many features are as follows:

- Extensive Powerful Graphical Data Displays
- Correlation Graphical Displays
- Extensive Hardware input options
- Built-in Corrosion Coupon Calculator
- Excel Import and Export Functions
- Easy Interfacing with DCS and SCADA Systems
- Multiple Database Exchange options
- Multi-Level Alarms
- Built-In Standard Reports
- Custom Report Generator
- Built-in powerful Calculator for easy set up of KPI's
- Log book for related data storage and linkage
- Log book links to graphical displays
- Logbook Search Function
- Properties Function for point related information
- Powerful Properties Search Tool
- RCS Remote Support

The power of the ICMS3 system is the potential return on investment that it can help you achieve. A recent customer had installed ICMS3 systems at three of their main gas processing plants. They had initially made significant savings in the plant operation that had paid for the system in the first 12 months. Later at one of the plants, management was becoming concerned with gradually increasing corrosion rates that were becoming major plant replacement and re-investment issues. A concerted study and analysis of the system was undertaken with the ICMS3 system over a 6 month period. The results of the findings from this study show that they will save an estimated \$50 million per year when the findings are implemented at all of their 11 plants.

RCS also provides remote access and support for its systems, typically over the internet through the client's secure VPN network. Security is a major concern for IT departments of all corporations these days. Through a VPN connection to our secure maintenance server, we provide a maintenance contract that provides the client with rapid support and assistance with data interpretation or system maintenance questions. As staffing levels get lower and less experienced staff are available, the comfort and security of system support is essential.

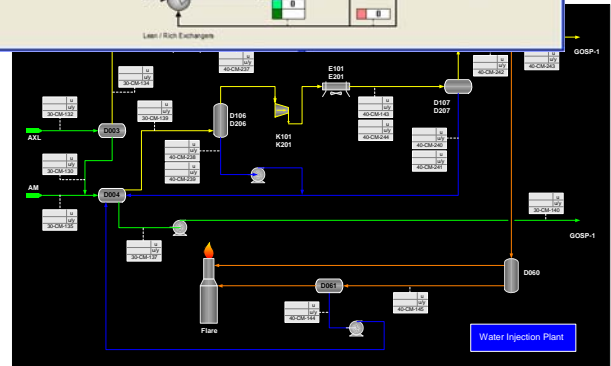
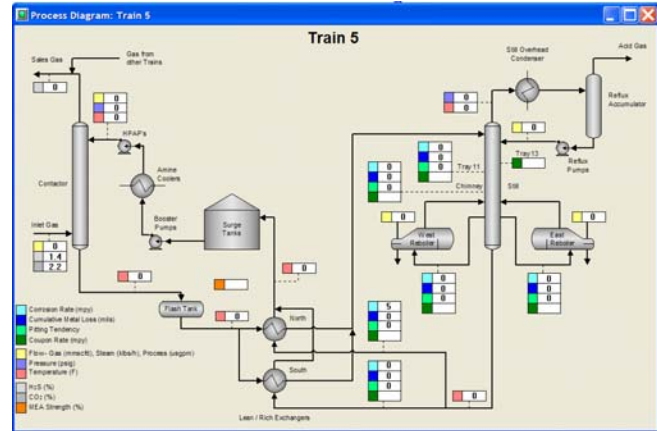

**Typical Mimic Diagrams**

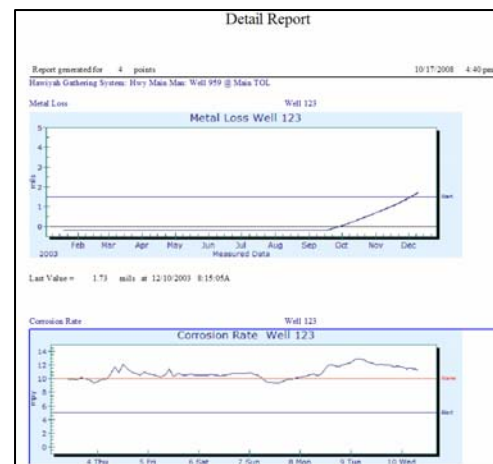

**Sample Standard Built-in Report**

	A	B	C	D	E
	Date/Time	Operators Daily MEA Strength Value (%)	Operators Daily Suck Filter Changes Value (Filter Changes)		
1					
2	9/16/2007 5:29:33 AM	15.4	9/15/2007 6:11:59 AM	11	2/17/2007 5:53:44 AM
3	9/24/2007 5:48:33 AM	16.1	9/24/2007 5:30:56 AM	9	3/7/2007
4	9/25/2007 6:09:35 AM	18.4	9/24/2007 5:49:55 AM	13	3/8/2007 8:26:56 PM
5	9/25/2007 6:09:39 AM	16.6	9/25/2007 6:10:42 AM	45	3/9/2007 5:54:06 AM
6	9/26/2007 6:07:02 AM	16.6	9/26/2007 6:07:23 AM	38	3/28/2007 6:09:18 AM
7	9/28/2007 5:47:59 AM	16.7	9/28/2007 5:48:26 AM	36	3/29/2007 6:04:52 AM
8	10/6/2007 5:26:54 AM	18	10/6/2007 5:27:20 AM	9	4/16/2007 6:48:23 PM
9	10/14/2007 6:02:27 AM	16.9	10/14/2007 6:02:43 AM	7	5/2/2007 6:11:20 AM
10	10/19/2007 6:03:29 AM	16.4	10/19/2007 6:03:43 AM	6	5/18/2007 5:43:27 AM
11	11/3/2007 5:47:52 AM	17.1	11/3/2007 5:48:31 AM	9	6/7/2007 5:10:20 AM
12					
13					

**Excel Import and Export Functions**

## Communication Options

There are many communication options available. It is a matter of selecting the best for the existing system. RCS can work with you to choose the most convenient and economical choice. The following options are available:

- Hardwire
  - RS-485 Multi-Drop - A single cable may be used to connect up to 32 transmitters (Microcor, Corratel, or Quicksand) with a single cable run
- Fibre Optic (Single or Multimode)
- Ethernet TCP/IP
- Modbus
- Radio
- Cellular/Lease Line
- Any other or existing transparent network

## RCS Design Service and Support

Every system will vary according to the application, and the infrastructure already in place. With networks and communications becoming more complex, it is difficult for corrosion specialist to be familiar with interfacing any corrosion monitoring system with the existing communications equipment and IT policies and requirements. RCS is happy to work with you and directly assist with your communications and IT departments to help analyze your best solutions and make easier the system design process.

RCS can provide this support from the initial design and specification stages through implementation and subsequent operation. Throughout our long history as the originators of these field monitoring systems we have earned a reputation for reliable performance and the commitment to follow the equipment into its successful field implementation, a service and support unmatched in any of our competitors.

Contact us for further assistance and remote access to a demonstration system at our California Headquarters over an internet link.

The above system elements are representative of typical on-line Corrosion Monitoring Systems. Each system is unique and can be designed to meet individual project specifications. For further information on the ICMS3 system and detailed ordering information contact RCS Customer Service Department at [sales@cosasco.com](mailto:sales@cosasco.com).

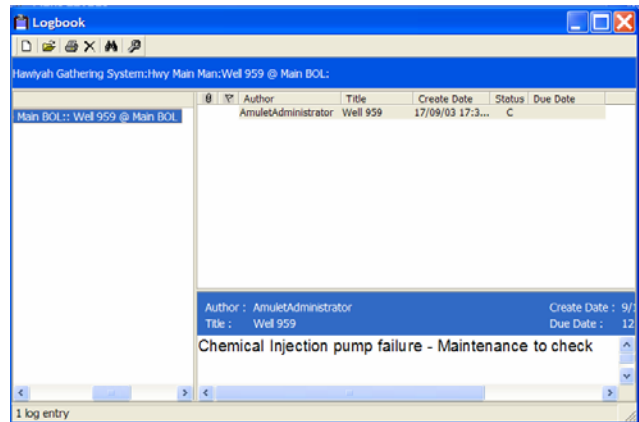

Logbook

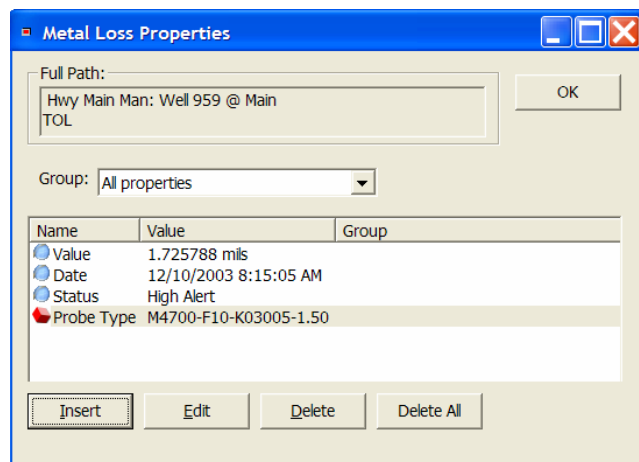

Properties Screen



Rohrback Cosasco Systems, Inc.  
11841 East Smith Avenue  
Santa Fe Springs, CA 90670, USA  
Tel: (1) 562-949-0123 Fax: (1) 562-949-3065  
US Toll Free: 800-635-6898  
E-Mail: [sales@cosasco.com](mailto:sales@cosasco.com)  
Web Site: [www.cosasco.com](http://www.cosasco.com)



ISO 9001:2008  
Certificate No. FM 10694