

Model CHECKMATE™ DL CORRDATA® Portable Instrument

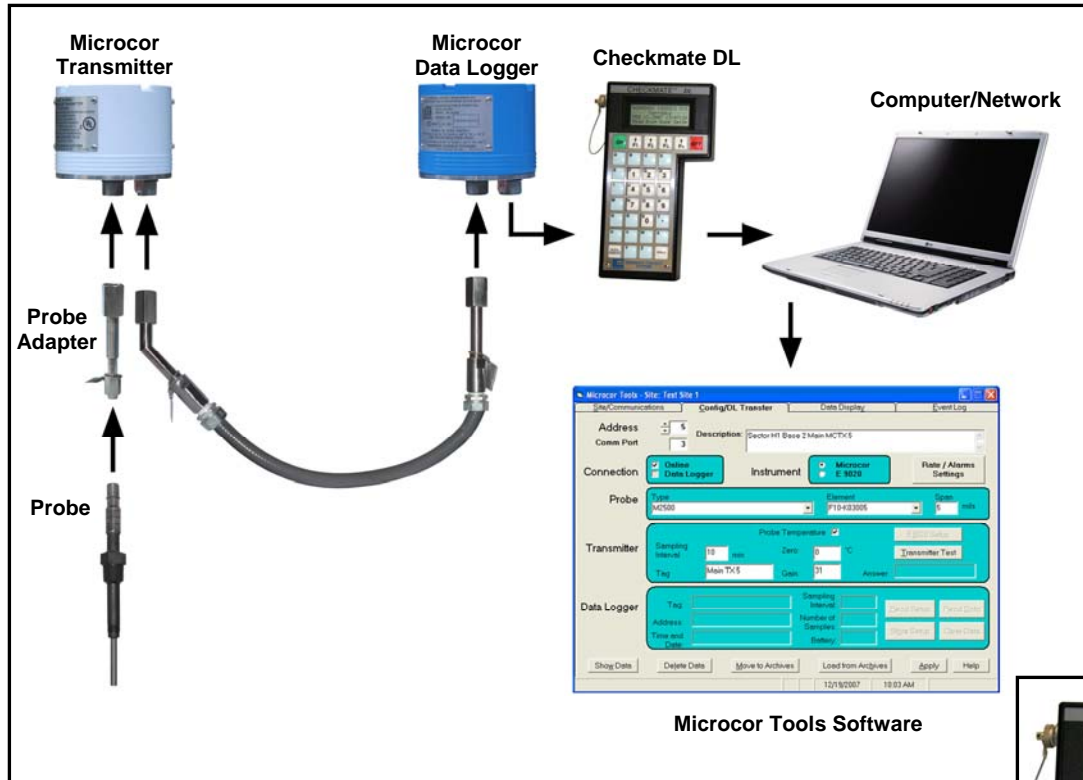

CHECKMATE™ DL shown with MICROCOR® data logging system. It can also be used with CORROSOMETER® and CORRATER® RDCs.

Features:

- Reads CORROSOMETER® and CORRATER® RDCs and all MICROCOR® Data loggers
- Downloads Stored Readings Directly to PC
- Certified for use in Hazardous Locations
- Intrinsically Safe

The CHECKMATE™ DL handheld instrument is the convenient and hassle-free way to program and collect data from MICROCOR® Data Loggers or CORROSOMETER® and CORRATER® Remote Data Collectors (RDC). CHECKMATE™ DL can be programmed to operate with either technology with only a few button clicks. This portable unit can store readings of up to 50 different MICROCOR® data loggers or CORROSOMETER® and CORRATER® RDCs. The intrinsically safe communication between the instrument and Data Loggers enables

the user to collect data without moving the Data Logger to a safe area. Furthermore, the CHECKMATE™ DL makes transferring stored data to a PC a much simpler process than before, using the CORRDATA® Corrosion Management Software or the MICROCOR® Tools Software.

The instrument is well suited for use in harsh field environments and certified for use in Class I, Zone 1 or Class 1, Zone 2 (Hazardous Locations).



Specifications:

- **Compatibility:**
 - All CORROSOMETER® and CORRATER® RDC units
 - All MICROCOR® Data loggers
- Memory for up to 50 RDCs when programmed with for CORRDATA® Systems. 57,330 MICROCOR® Data Logger Readings when programmed for MICROCOR® Systems.
- **Data Transfer:** Intrinsically Safe RS 232 at 9600 Baud Rate
- **Power Source:** 6 AA Alkaline Batteries
- **Battery Life:** Typically 10 hours of continuous operation
- **Display:** Four Line Liquid Crystal Display (LCD)
- **Temperature Range:**
 - Operating:** 0°F to 122°F (-18°C to 50°C)
 - Storage:** 0°F to 150°F (-18°C to 65°C)
- **Enclosure:** Splash-proof enclosure with sealed membrane keyboard
- **Dimensions:** 7.75"H x 4.30"W x 2"D
(196.8 mm x 109.2 mm x 50.8 mm)
- **Weight without carrying case:** 1.5 lbs. (0.68 kg)
- **Weight with carrying case:** 5 lbs (2.3kg)

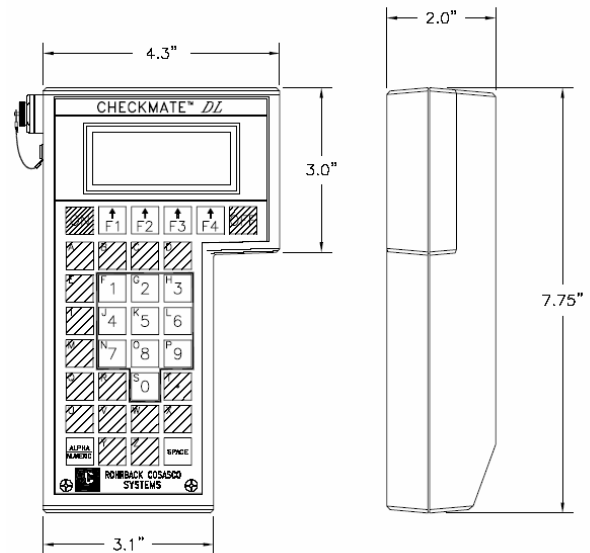

- **Hazardous Area Certification:**

- **Model CHECKMATE-DL-0-Y: Class 1, Zone 2**

- North America:

- UL AEx nL IIC T4 Tamb = -20°C to +50°C

- ULc Ex nL IIC T4 Tamb = -20°C to +50°C

- Europe:

- CE compliant (EMC, ATEX)

- ATEX EEx nL IIC T4 Tamb = -20°C to +50°C

- **Model CHECKMATE-DL-1-Y: Class 1, Zone 1**

- North America:

- UL AEx ib IIC T4 Tamb = -20°C to +50°C

- ULc Ex ib IIC T4 Tamb = -20°C to +50°C

- Europe:

- CE compliant (EMC, ATEX)

- ATEX EEx ib IIC T4 Tamb = -20°C to +50°C

Ordering Information:

Model	Description	
CHECKMATE-DL	Portable CORRDATA® Data Logging Instrument With Carrying Case	
↓	Code	Certification (Z)
	1	Intrinsically Safe
CHECKMATE-DL	— 1	Example

Accessories: Field carrying case, Leather – P/N 723631



Rohrback Cosasco Systems, Inc.
 11841 East Smith Avenue
 Santa Fe Springs, CA 90670, USA
 Tel: (1) 562-949-0123 Fax: (1) 562-949-3065
 US Toll Free: 800-635-6898
 E-Mail: sales@cosasco.com
 Web Site: www.cosasco.com



ISO 9001:2008
 Certificate No. FM 10694